



CONCEPTWALL 50 CURTAIN WALL

ConceptWall 50 is a versatile aluminum curtain wall system designed to create high-performance glazed façades across a wide range of architectural applications.

The system combines thermal insulation and structural stability, enabling large glass surfaces while maintaining energy efficiency and reliable weather performance. Based on a stick system, it supports efficient on-site assembly and consistent execution.

Engineered for flexibility, ConceptWall 50 supports multiple façade configurations and integrates with window and door systems, making it suitable for residential and commercial projects.

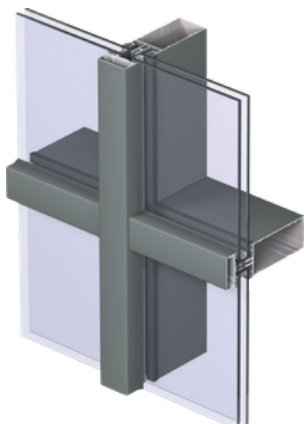

- MADE IN CANADA
- HIGH PERFORMANCE ALUMINUM SYSTEMS FROM REYNAERS
- SOBINCO ACCESORIES

nordicaaluminum.com
sales@nordicaaluminum.com - 604-971-6736

PERFORMANCE HIGHLIGHTS

- **Passive House Certified HI Variant:** High-insulation configuration certified by the Passive House Institute for advanced energy-efficient façade systems.
- **High-Performance Façade System:** Designed to support large glazed areas with consistent structural and thermal performance
- **Reliable Weather Performance:** Air infiltration of 0.02 cfm/ft³ and water resistance up to 15 psf
- **Thermal Performance:** Achieves insulation values of U_w 0.23 (double glazing) and U_w 0.14 (triple glazing)
- **Structural Capacity:** Supports glazing weights up to 1543 lbs, enabling large-span façade application
- **Acoustic Performance:** Up to STC 41 dB and OITC 35 dB for improved interior comfort
- **Design Flexibility:** Supports a wide range of façade configurations and integrates with window and door systems

NORDICA
aluminum

A division of  open windows